

Bird Control Division

IndoDivert™ – Bird Flight Diverter

Savior of Avian Species
Boon for Power Transmission Companies

Specially designed to endure harsh weather conditions

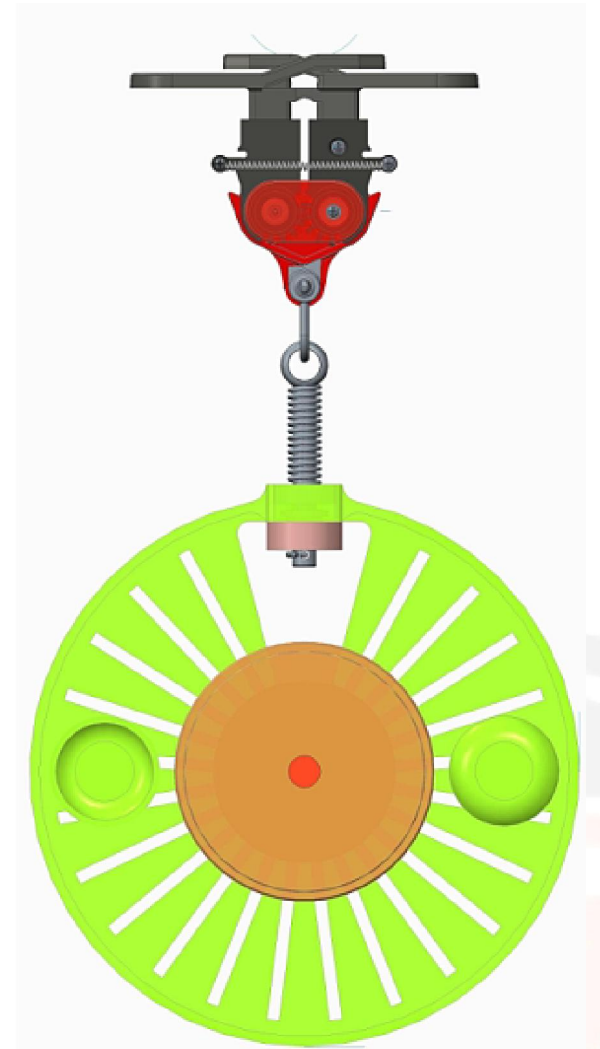

Indolite Devices Pvt.Ltd

Bird, Monkey & Wild Life Control Solutions



About Indolite™

Product Philosophy:

- ❑ We endeavor towards **COHABITATION** of humans and wild life. We strive for safety of birds and animals.
- ❑ Indolite Devices Pvt. Ltd. is a MSME (Govt. of India) recognized business enterprise. It is an **ISO 9001:2015, ISO 14001:2015, HACCP, RoHS, GMP, and “CE”** certified company and perhaps, has one of the world's largest range of professional bird, monkey and wild life control solutions.

Sectors covered:

- ❑ **Indolite™** products are useful and equally effective in transmission lines, commercial, industrial, residential properties as well as in resorts etc.

Product Philosophy:

- ❑ Our products are either **DETERRENTS** or **BARRIERS**. None of our solutions is fatal.

Manufacturing Base:

- ❑ Indolite™ holds marketing & manufacturing licensees of various patents to manufacture IndoDivert™, BirdScare™, MonkeyScare™, product range in India.

High In-house R&D

- ❑ Indolite™ has in-house research & development team besides designing and manufacturing facilities.

Indolite Devices Pvt.Ltd

International Certifications

We are an ISO 9001:2015 & ISO 14001:2015 certified company.



CERTIFICATE OF REGISTRATION

Quality Management System
of
INDOLITE DEVICES PVT.LTD
ADD: 18, Raja Garden, New Delhi - 110015 (INDIA)

CQMS Services Pvt. Ltd. certifies that the Management System of the above mentioned organization has been assessed and meets the requirements of following standard:

ISO 9001:2015 (Q.M.S.)

For the scope of following activities:

Manufactures of Service Providers of Bird & Wildlife Control Products, Engineering Products, RFID & AFC Systems, Access Barriers, Electronic Controls, Energy Saving Devices, Plastic & Rubber Components, Material Handling & Storage Systems, Road Safety Products.

Certificate No: CQMS210518Z	1st Surv. Due Before: 2019/May/16
Issue Date: 2018/May/21	2nd Surv. Due Before: 2020/May/16
Valid Till: 2021/May/20	Re-certification Due Before: 2021/May/16

Note: After successful completion of surveillance audit, certificate continuation letter shall be issued.

In the course of validity of the present certificate the enterprise management system must permanently satisfy the requirements of the international regulations. The fulfillment of these regulations will be regularly controlled by CQMS Services Pvt. Ltd.

CQMS Services Pvt.Ltd
Certification of Quality Management System.

www.certificationqms.com





H.O: B-53A, Shashi Garden Mayur Vihar Ph-1, B.O: Vishwakarma Industries Area Meerut-250001, U.P.



CERTIFICATE OF REGISTRATION

Quality Management System
of
INDOLITE DEVICES PVT.LTD
ADD: 18, Raja Garden, New Delhi - 110015 (INDIA)

CQMS Services Pvt. Ltd. certifies that the Management System of the above mentioned organization has been assessed and meets the requirements of following standard:

ISO 14001:2015 (E.M.S)

For the scope of following activities:

Manufactures of Service Providers of Bird & Wildlife Control Products, Engineering Products, RFID & AFC Systems, Access Barriers, Electronic Controls, Energy Saving Devices, Plastic & Rubber Components, Material Handling & Storage Systems, Road Safety Products.

Certificate No: CQMS220518Q	1st Surv. Due Before: 2019/May/17
Issue Date: 2018/May/22	2nd Surv. Due Before: 2020/May/17
Valid Till: 2021/May/21	Re-certification Due Before: 2021/May/17

Note: After successful completion of surveillance audit, certificate continuation letter shall be issued.

In the course of validity of the present certificate the enterprise management system must permanently satisfy the requirements of the international regulations. The fulfillment of these regulations will be regularly controlled by CQMS Services Pvt. Ltd.

CQMS Services Pvt.Ltd
Certification of Quality Management System.

www.certificationqms.com





H.O: B-53A, Shashi Garden Mayur Vihar Ph-1, B.O: Vishwakarma Industries Area Meerut-250001, U.P.



CERTIFICATE OF REGISTRATION

Quality Management System
of
INDOLITE DEVICES PVT.LTD
ADD: 18, Raja Garden, New Delhi - 110015 (INDIA)

CQMS Services Pvt. Ltd. certifies that the Management System of the above mentioned organization has been assessed and meets the requirements of following standard:

OHSAS

For the scope of following activities:

Manufactures of Service Providers of Bird & Wildlife Control Products, Engineering Products, RFID & AFC Systems, Access Barriers, Electronic Controls, Energy Saving Devices, Plastic & Rubber Components, Material Handling & Storage Systems, Road Safety Products.



Certificate No: CQMS250518A	1st Surv. Due Before: 2019/May/20
Issue Date: 2018/May/25	2nd Surv. Due Before: 2020/May/20
Valid Till: 2021/May/24	Re-certification Due Before: 2021/May/20

Note: After successful completion of surveillance audit, certificate continuation letter shall be issued.

In the course of validity of the present certificate the enterprise management system must permanently satisfy the requirements of the international regulations. The fulfillment of these regulations will be regularly controlled by CQMS Services Pvt. Ltd.

CQMS Services Pvt.Ltd
Certification of Quality Management System.

www.certificationqms.com



H.O: B-53A, Shashi Garden Mayur Vihar Ph-1, B.O: Vishwakarma Industries Area Meerut-250001, U.P.

International Certifications

We are also OHSAS 18001:20015 ROHS & "CE" compliant.



CERTIFICATE OF REGISTRATION

Quality Management System
of
INDOLITE DEVICES PVT.LTD
ADD: 18, Raja Garden, New Delhi - 110015 (INDIA)

CQMS Services Pvt. Ltd. certifies that the Management System of the above mentioned organization has been assessed and meets the requirements of following standard:

HACCP

For the scope of following activities:

Manufactures of Service Providers of Bird & Wildlife Control Products, Engineering Products, RFID & AFC Systems, Access Barriers, Electronic Controls, Energy Saving Devices, Plastic & Rubber Components, Material Handling & Storage Systems, Road Safety Products.

Certificate No: CQMS240518Q	1st Surv. Due Before: 2019/May/19
Issue Date: 2018/May/24	2nd Surv. Due Before: 2020/May/19
Valid Till: 2021/May/23	Re-certification Due Before: 2021/May/19

Note: After successful completion of surveillance audit, certificate continuation letter shall be issued.

In the course of validity of the present certificate the enterprise management system must permanently satisfy the requirements of the international regulations. The fulfillment of these regulations will be regularly controlled by CQMS Services Pvt. Ltd.

CQMS Services Pvt.Ltd
Certification of Quality Management System.

www.certificationqms.com





H.O: B-53A, Shashi Garden Mayur Vihar Ph-1, B.O: Vishwakarma Industries Area Meerut-250001, U.P.



CERTIFICATE OF REGISTRATION

Quality Management System
of
INDOLITE DEVICES PVT.LTD
ADD: 18, Raja Garden, New Delhi - 110015 (INDIA)

CQMS Services Pvt. Ltd. certifies that the Management System of the above mentioned organization has been assessed and meets the requirements of following standard:

GMP

For the scope of following activities:

Manufactures of Service Providers of Bird & Wildlife Control Products, Engineering Products, RFID & AFC Systems, Access Barriers, Electronic Controls, Energy Saving Devices, Plastic & Rubber Components, Material Handling & Storage Systems, Road Safety Products.

Certificate No: CQMS230518A	1st Surv. Due Before: 2019/May/18
Issue Date: 2018/May/23	2nd Surv. Due Before: 2020/May/18
Valid Till: 2021/May/22	Re-certification Due Before: 2021/May/18

Note: After successful completion of surveillance audit, certificate continuation letter shall be issued.

In the course of validity of the present certificate the enterprise management system must permanently satisfy the requirements of the international regulations. The fulfillment of these regulations will be regularly controlled by CQMS Services Pvt. Ltd.



CQMS Services Pvt.Ltd
Certification of Quality Management System.

www.certificationqms.com





H.O: B-53A, Shashi Garden Mayur Vihar Ph-1, B.O: Vishwakarma Industries Area Meerut-250001, U.P.

CERTIFICATE OF REGISTRATION

Quality Management System
of
INDOLITE DEVICES PVT.LTD
ADD: 18, Raja Garden, New Delhi - 110015 (INDIA)
Certificate of Compliance

CQMS Services Pvt. Ltd. certifies that the Management System of the above mentioned organization has been assessed and meets the requirements of following standard:

RoHS Directive (2002/95/EC)

On use certain Hazardous Substances in Electrical and Lighting Equipments.
For the scope of following activities:

Product Description: Bird & Wildlife Control Products, RFID & AFC Systems, Access Barriers, Energy Saving Devices & Road Safety Products, Electronic Controls.





Certificate No: CQMS260518A	1st Surv. Due Before: 2019/May/20
Issue Date: 2018/May/26	2nd Surv. Due Before: 2020/May/20
Valid Till: 2021/May/25	Re-certification Due Before: 2021/May/20

Note: After successful completion of surveillance audit, certificate continuation letter shall be issued.









In the course of validity of the present certificate the enterprise management system must permanently satisfy the requirements of the international regulations. The fulfillment of these regulations will be regularly controlled by CQMS Services Pvt. Ltd.

CQMS Services Pvt.Ltd
Certification of Quality Management System.

www.certificationqms.com

H.O: B-53A, Shashi Garden Mayur Vihar Ph-1, B.O: Vishwakarma Industries Area Meerut-250001, U.P.

Client	
	<p>Kalpataru Power Transmission Limited</p>
	<p>Power Grid Corporation Of India Limited</p>
	<p>Tata Power Ltd.</p>
	<p>Tata Power Solar Limited</p>
	<p>Vestas</p>
	<p>Saurya Urja Company of Rajasthan Limited</p>
	<p>CESC</p>
	<p>STERLITE POWER LIMITED</p>

Pvt.Ltd

Clients

Bird Accident with Transmission Line is Hazardous



Bird, Monkey & Wild Life Control Solutions

Indolite Devices Pvt.Ltd



Placement of Bird Diverter

Recommended by:

Wildlife Institute of India - Dehradun

Citation: Power-Line Mitigation Measures (2018)

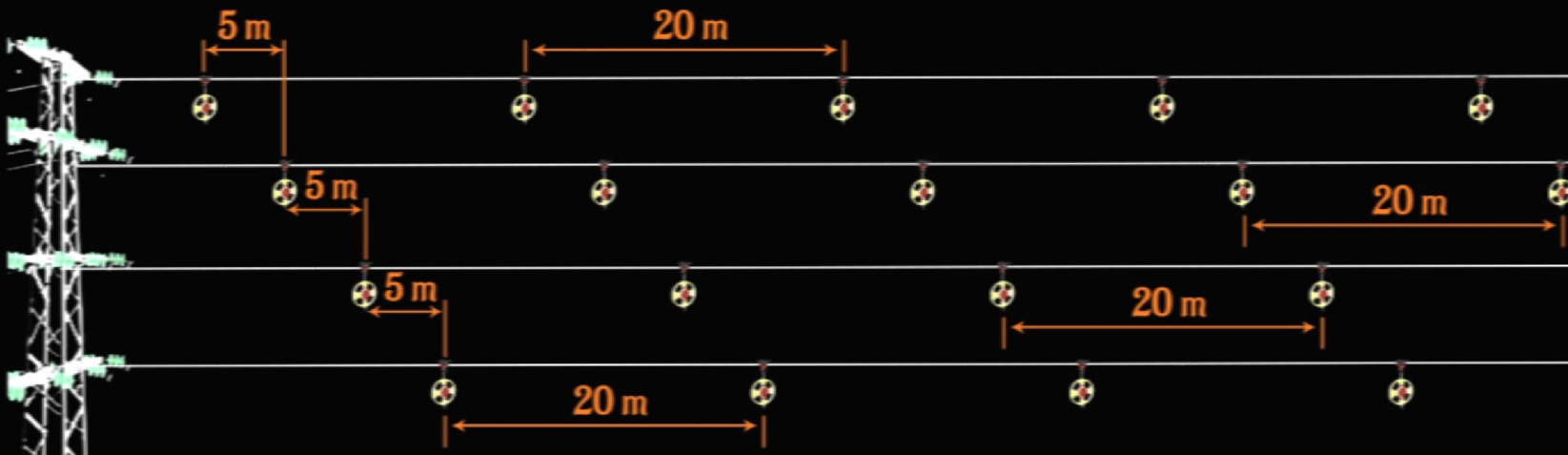

Indolite Devices Pvt.Ltd

Bird, Monkey & Wild Life Control Solutions



IndoDiverter™ Bird Flight Diverter

Push to Lock

Patent protected



Designed for quick installation.

String is provided between both clamps, which eases installation and saves time.

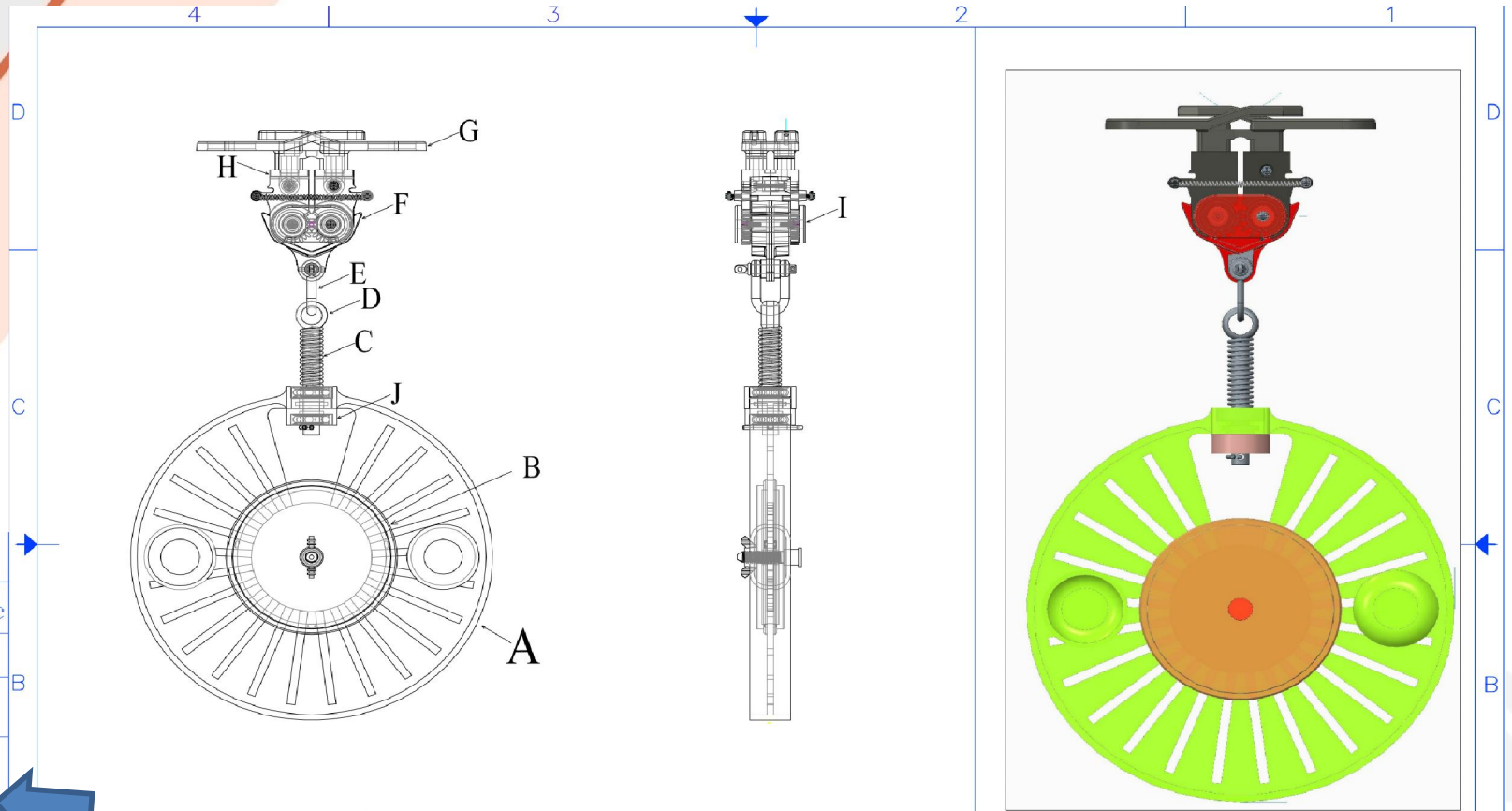

Component Details

S.No.	Description	Material	Qty / Pc
A.	Dangler	UV Stabilized, Flame Retardent PC	1
B.	Reflector	PMMA	2
C.	Spring	Stainless Steel	1
D.	Suspension Rod	Stainless Steel	3
E.	D-Shackle	Stainless Steel	3
F.	Yoke	UV Stabilized PC	1
G.	Clamp 10-20	PA 6/6 GF 30%	2
H.	Gear Box	PA 6/6 GF 30%	2
I.	Axis Flange	UV Stabilized PC	2
J.	Bearing Housing	Aluminium	1

Component Details

S.No.	Description	Material	Qty / Pc
A.	Dangler	UV Stabilized, Flame Retardent PC	1
B.	Reflector	PMMA	2
C.	Spring	Stainless Steel	1
D.	Suspension Rod	Stainless Steel	3
E.	D-Shackle	Stainless Steel	3
F.	Yoke	UV Stabilized PC	1
G.	Clamp 10-20	PA 6/6 GF 30%	2
H.	Gear Box	PA 6/6 GF 30%	2
I.	Axis Flange	UV Stabilized PC	2
J.	Bearing Housing	Aluminium	1

Amendment	Model	DATE	Scale	TOL.. ±5 %
PART NO. Assy.	BD-05	01-02-2016	N T S	Construction Material:
Title - IndoDivert™: Bird Flight Diverter		UOM: Piece		PC & PA 6/6 GF 30% , Stainless Steel
Classification: Wild Life Conservation & Safety		Weight: Approx 0.55 Kg		ALL DIM IN mm.
				DRN.BY S.Singh
				APPD.BY Maninder
				DRW.No. Indo-BD-05-01
				WEBSITE
				www.indolite.com
Indolite Devices Pvt Ltd 18, Raja Garden, New Delhi 110 015 India				

Indolite Devices Pvt.Ltd

About IndoDiverter™

BIRDS STRIKE IS A MAJOR PROBLEM FOR POWER TRANSMISSION COMPANIES

& *Hazardous for Endangered Avian Species*

For safety reasons, high powered power transmission lines are placed very high; however, for avian species, these overhead conductors are a potentially fatal obstacle. Under low visibility conditions, birds sometimes fly into power lines.

Birds collide with overhead structures and conductors, damage insulators and equipment leading to customer interruptions.

On the other side, birds don't always get friendly treatment from power distributors either. They are electrocuted, maimed and not so gently encouraged to stay off certain areas of our T&D system. We need to explore ways to cohabitate with birds so that the impact of their flight, perching and nesting habits leads to minimal power disturbances.

Preventative measures also should be taken to safeguard birds, especially the more than 800 species of protected migratory birds in India.

Equipment can be replaced, but loss of endangered species, once extinct, cannot be recuperated.



Indolite Devices Pvt.Ltd



About IndoDivert™

ALL SORTS OF PROBLEMS

Birds cause damage and disruptions in many ways. Their size, type and habitat all contribute to the potential negative impact they can have on the power grid. Larger predatory birds like raptors cause some of the more challenging problems. The Edison Electric Institute identified reasons why raptors are attracted to power lines: Poles increase their range of vision and attack speed when hunting; they provide good hunting and roosting platforms; they are favorable sites for raptors to broadcast territory boundaries; and a good prey base exists along rights of ways. The contributing factors for raptors becoming electrocuted were identified as:

Species

Large raptors like golden eagles, red-tailed hawks and great-horned owls are more perilous.

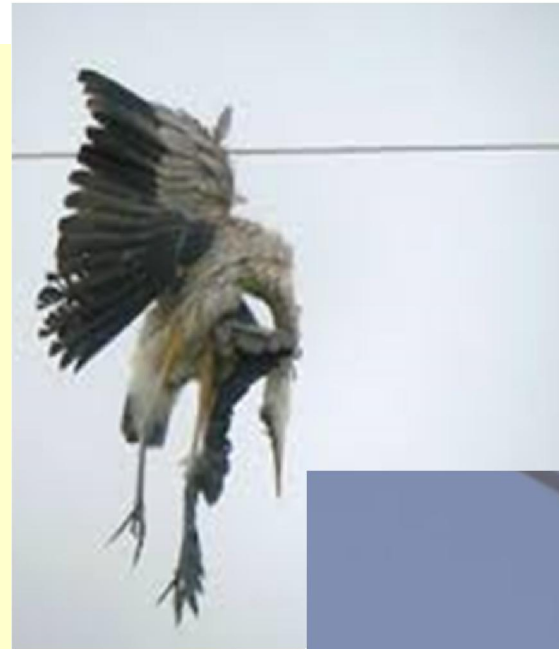

IndoDivert™ Bird Flight Diverter

- Birds sometimes may not notice presence of electrical conductors in their flight path.
- This leads to accidents, which may be fatal.
- **IndoDivert™** is designed to dangle on conductors and reveal presence of conductors.



Indolite Devices Pvt.Ltd

Special additives added to make it glow in dark and emit UV light.

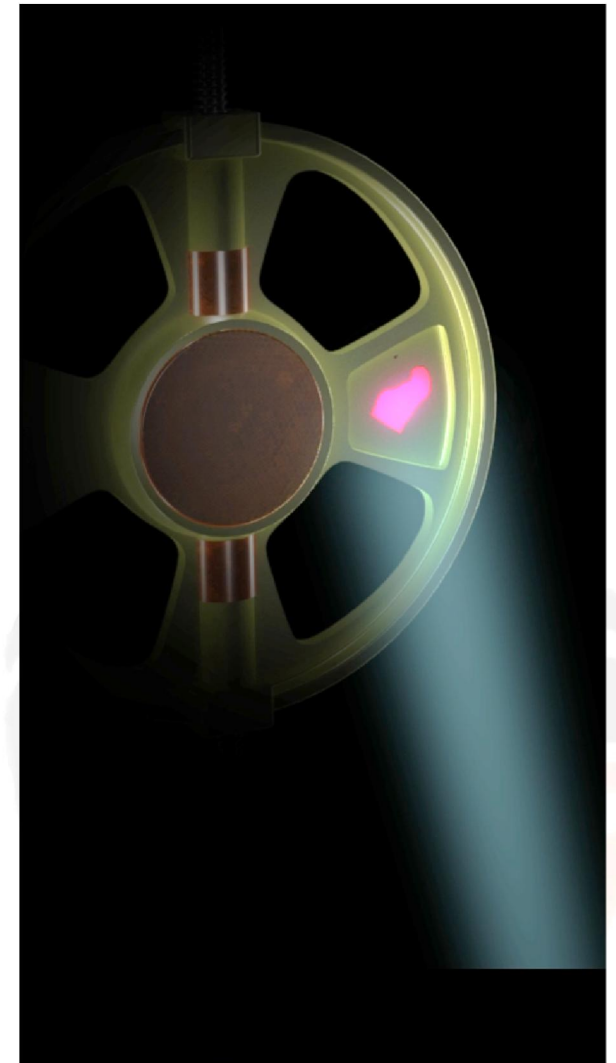

Indolite Devices Pvt.Ltd

IndoDivert™ Bird Flight Diverter

Effective for : All avian species and bats.

IndoDivert™ to be used on: On power lines and communications towers.

Dangler Material: Impact-resistant, UV-stabilized and heat resistant (-20°C to 100°C.) Large Dangler Diameter (225mm) for good visibility.

Glow in dark makes it visible during dark.

For Rotating Assistance:

- *Weather resistant, Corrosion free, Super strong, Self lubricated bearings, made using special grade of steel are used.*
- *Low friction parts help in rotation and swivel movement.*

Inverse Pockets created on both faces of disk. These help in trapping air, resulting - rotation of disk even in very low wind pressure.

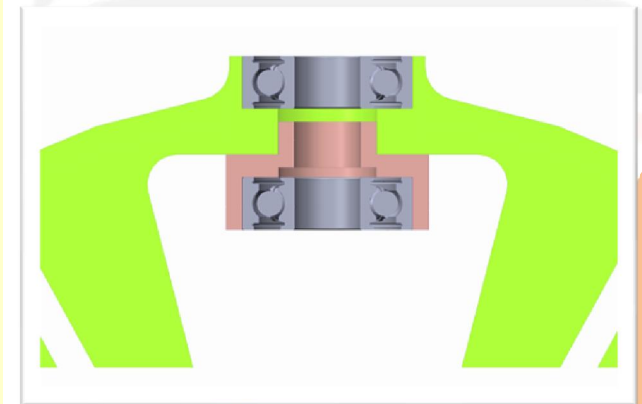
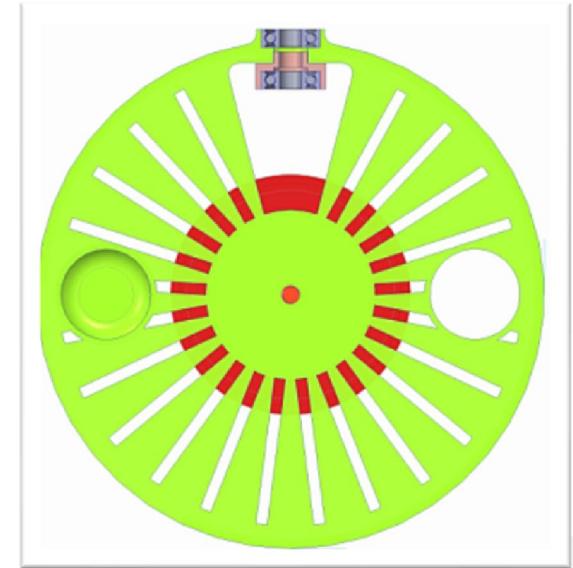

Indolite Devices Pvt.Ltd

IndoDivert™ Bird Flight Diverter

- Stainless steel axis pin adds to strength and life.
- Two sets of corrosion resistant, self lubricating bearings are used for friction less rotation.
- This endows smooth and easy rotation of **IndoDivert™**.
- Air Pockets assist rotation
- Titanium alloy/ Stainless steel springs impart constant holding pressure on this mechanism, resulting in strong grip.

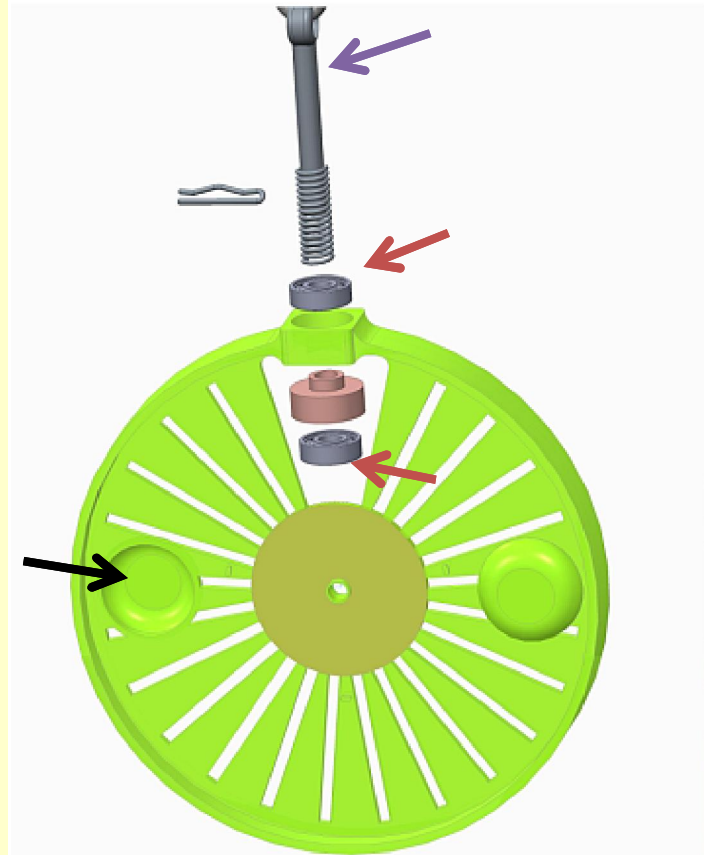

IndoDivert™ Bird Flight Diverter

- Large birds cannot manoeuvre their flight path easily.
- **IndoDivert™** is very effective in giving well timed alarm to birds about presence of obstruction in their flight path **hence giving the bird more opportunity to change direction helping in save bird's life and the power line.**
- This helps not only large birds likes Swans, eagles but also to aircrafts to veer upwards in flight.
- Birds can see in multiple light ranges – visible / ultra-violet. IndoDivert™ is designed to use peak vision ranges of light visible to birds (360nm/560nm wavelengths). A bird's vision utilizes both light and motion – both components of IndoDivert™. The angle of light refraction, static or active wind conditions alert approaching birds to divert their flight patterns.



Indolite Devices Pvt.Ltd

IndoDivert™ Bird Flight Diverter

- As compared with normal colours - Ultraviolet light/colours are more visible to birds.
- **IndoDivert™** emits ultraviolet light during day whereas - **Special additives are added to make in glow in dark. This provides extra safety.**

Flight Path: **IndoDivert™** is installed on all levels of power lines or cell tower guy wires. This attracts avian vision, thereby reduces collision.

The Rotating mechanism increases effectiveness. Clamping brackets can be adapted to almost any environmental / structural condition.

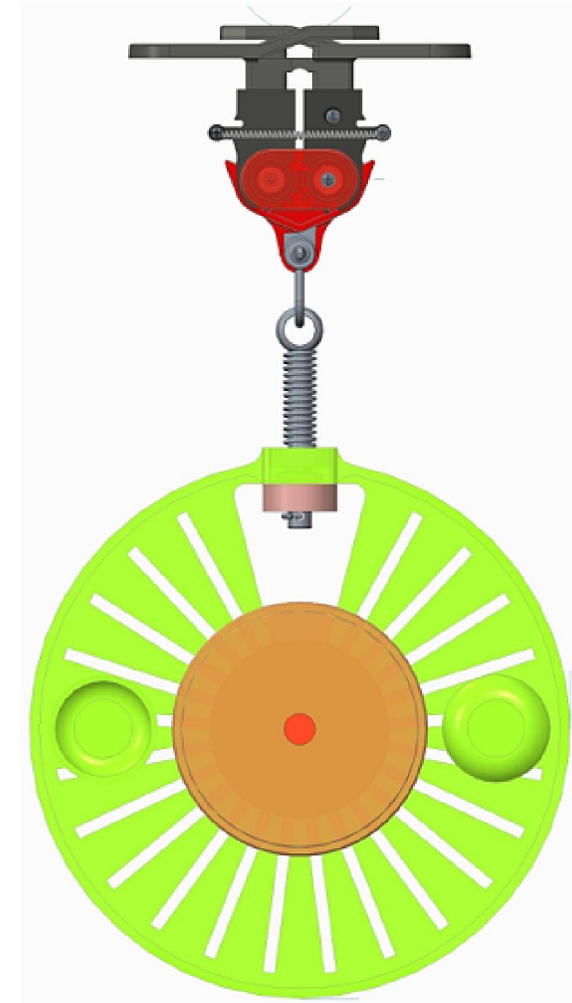

Indolite Devices Pvt.Ltd

IndoDiverter™ Bird Flight Diverter

- Combination of multiple colours is used to increase visibility.
- Red and Amber reflectors are fixed in the middle of DANGLER. These reflect sunlight and moonlight cautioning not only the birds, but also to airplanes and helicopters.
- Using natural flow of wind, Dangler rotates, shudders and flaps. This acts as an alarm to birds and adds to visibility.
- Our improved model has cups on alternate side of disk and stainless steel chain link suspension system.

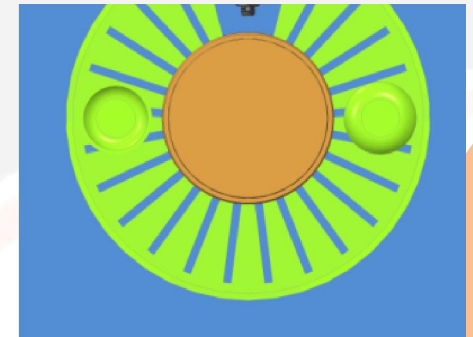
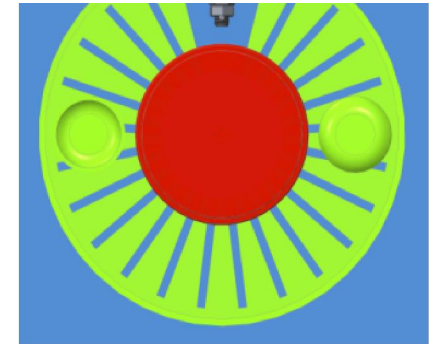

IndoDivert™ Bird Flight Diverter

- Easy mounting makes **IndoDivert™** user friendly.
- To hang from conductor, spring loaded clamp is kept in open position.
- In open position, a string mounted on bracket is exposed.
- While loading, string is pushed down by conductor, whereas clamps are pushed upwards. This activates spring and clamp grips the conductor firmly.
- Flexible stainless suspension system is used to hang dangler from bracket. This helps in easy movement of dangler even during low wind conditions.

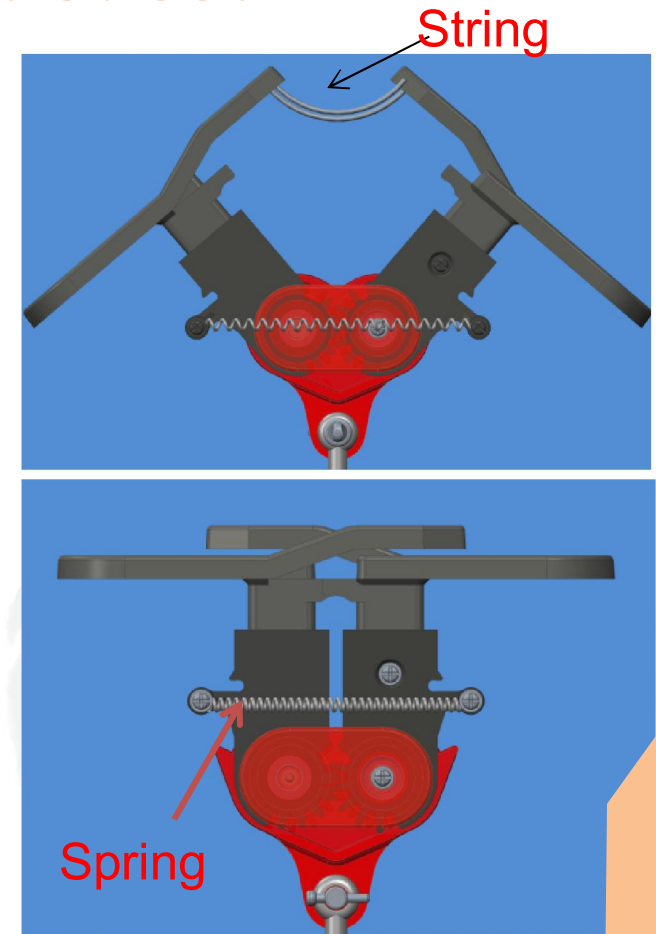

- Gear box arrangement ensures uniform holding pressure and grip.

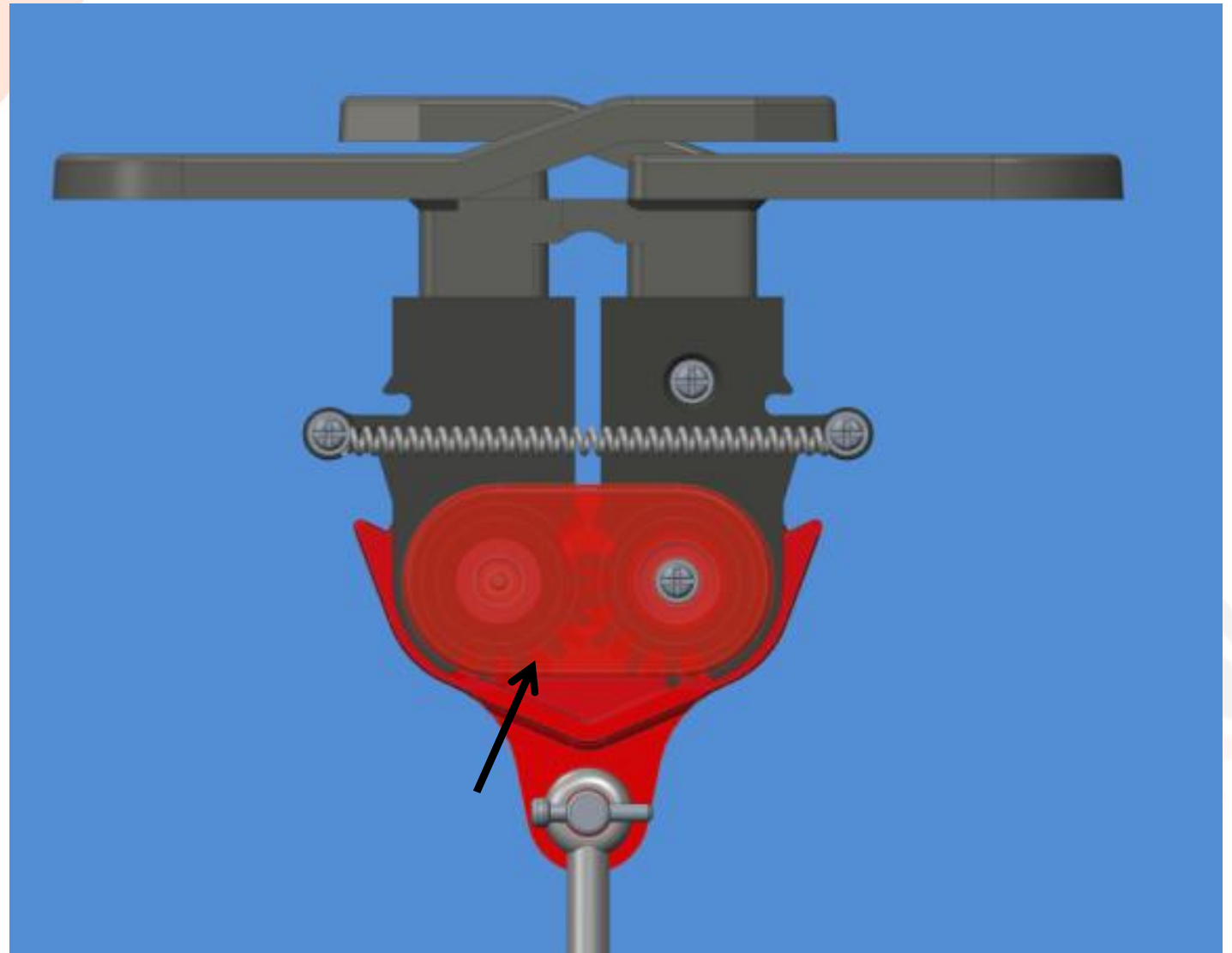

Designed to swing and rotate simultaneously.



IndoDivert™ Bird Flight Diverter

- Can be mounted on conductors, maintaining safe distance, using fire stick.
- Clamp available for OPGW and ACSR conductors.
- Utmost care is taken in choosing raw materials for making parts of **IndoDivert™**
- Levers of clamp, gear box and dangler are made using U.V. stabilized material whereas spring and suspension system is made using stainless steel.
- Special consideration is given to minimize it's weight .
- Chain link suspension eases flapping movement. This also increases life of IndoDivert™

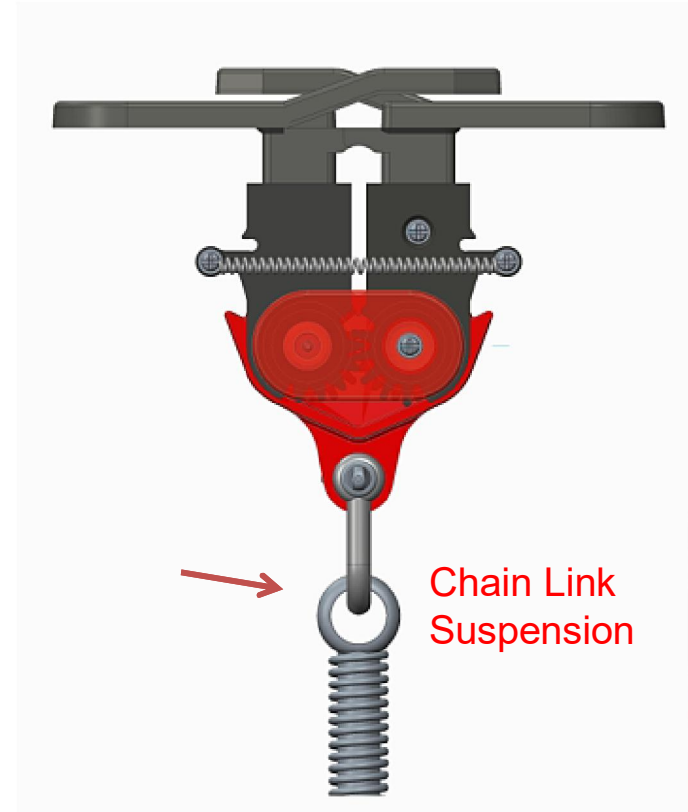

Placement of IndoDivert™

- For example, if there are 4 rows of conductors (1 earth + 3 phases), then first diverter is hung from the top (earth) conductor, at 5m from tower.
- Second diverter is hung on top phase conductor at a distance of approx 5 meters from first diverter.
- 3rd on middle phase conductor, at a distance of approx 5 meters from 2nd diverter.
- Fourth diverter is clamped on lowest conductor at a distance of 5 meters from 3rd diverter.
- 5th diverter on middle phase conductor at a distance of 5 meters from 4th diverter.
- 6th Diverter on top phase conductor at a distance of 5 meters from 5th diverter.
- 7th diverter is again clamped on earth wire. at a distance of 5 meters from 6th diverter
- This way linear distance between each diverter is 20 meters (or ~ 66 feet), but when looked from distance, it looks like a constellation of diverters.

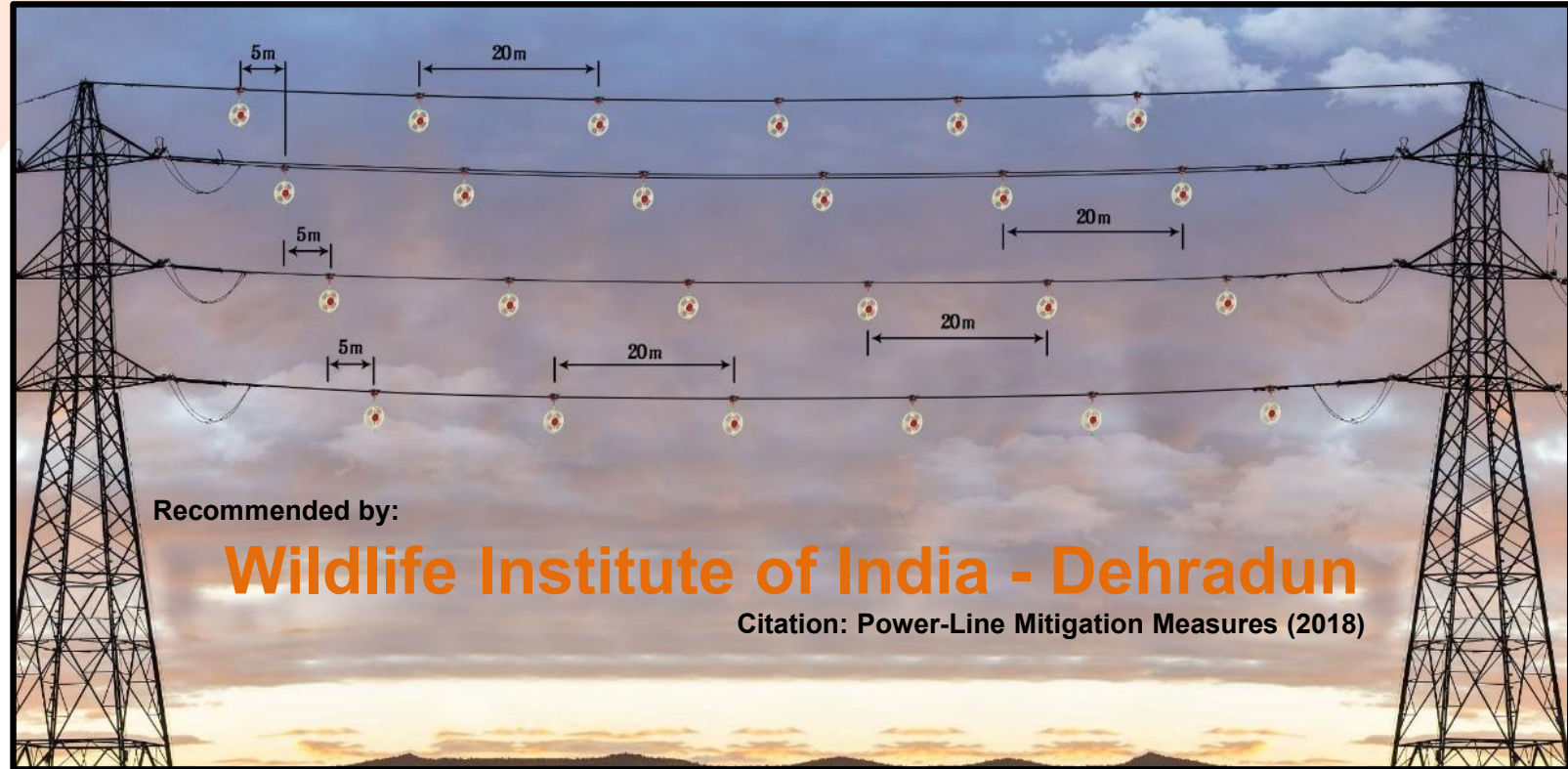

IndoDiver™ Bird Flight Diverter

Test Certificates from NABL Accredited Laboratory

atcc **AMIT TEST AND CALIBRATION CENTRE**
(NABL ACCREDITED LABORATORY)
Kh.No. 45/14, 17 & 45/6 & 7 Village Prahaladpur Bangar, Near Kali Mata Mandir, Delhi-110042
Ph.: 011-66561602, 65651603 Email: amitacc2@gmail.com Website : www.atcc.in

TEST REPORT
Test Certificate No. : ATCC/18051501
Issue Date : 18.05.2018
Job order No. : 18051501
Test to be Conducted, As Per Party Requirement
Date of Test : 18.05.2018
Date of Sample Received : 15.05.2018
Party Ref. No. INDOMS/05/2018/60 Dated 16.05.2018

Quantity of Sample : 1 No
Sample Description : Indo Diver™ Bird Flight diverter (Model - BD-05)



Sl.No.	Test Conducted, Specification As Per Party Requirement	Specified Value	Test Results
1	Slip & Fall Test		114 Kg

XXXXXXX END OF TEST REPORT XXXXXXX

Notes
(1) This Test Report refers only to the particular sample(s) submitted for testing. (2) This Test Report shall not be reproduced, except in full, unless written permission for the publication of an approved abstract has been obtained from the CEO, Amit Test and Calibration Centre, New Delhi. (3) Test Report shall not be utilized for any legal purpose and will not be produced in the court of law & no responsibility would be attached. Amit Test and Calibration Centre. (4) The test results reported in this certificate are valid at the time of and under the stated conditions of measurements.

MANOHAR SINGH JADON
Issued By: 
(C.E.O.)

Authorized Signatory 2 of 2
SADHANA JADON
(Quality Manager)

atcc **AMIT TEST AND CALIBRATION CENTRE**
(NABL ACCREDITED LABORATORY)
Kh.No. 45/14, 17 & 45/6 & 7 Village Prahaladpur Bangar, Near Kali Mata Mandir, Delhi-110042
Ph.: 011-66561602, 65651603 Email: amitacc2@gmail.com Website : www.atcc.in

TEST REPORT
Test Certificate No. : ATCC/18051501
Issue Date : 18.05.2018
Job order No. : 18051501
Test to be Conducted, As Per Party Requirement
Date of Test : 18.05.2018
Date of Sample Received : 15.05.2018
Party Ref. No. INDOMS/05/2018/60 Dated 16.05.2018



Quantity of Sample : 1 No
Sample Description : Indo Diver™ Bird flight diverter (Model no.BD-05)



Notes
(1) This Test Report refers only to the particular sample(s) submitted for testing. (2) This Test Report shall not be reproduced, except in full, unless written permission for the publication of an approved abstract has been obtained from the CEO, Amit Test and Calibration Centre, New Delhi. (3) Test Report shall not be utilized for any legal purpose and will not be produced in the court of law & no responsibility would be attached. Amit Test and Calibration Centre. (4) The test results reported in this certificate are valid at the time of and under the stated conditions of measurements.

MANOHAR SINGH JADON
Issued By: 
(C.E.O.)

Authorized Signatory 2 of 2
SADHANA JADON
(Quality Manager)

atcc **AMIT TEST AND CALIBRATION CENTRE**
(NABL ACCREDITED LABORATORY)
Kh.No. 45/14, 17 & 45/6 & 7 Village Prahaladpur Bangar, Near Kali Mata Mandir, Delhi-110042
Ph.: 011-66561602, 65651603 Email: amitacc2@gmail.com Website : www.atcc.in

TEST REPORT
Test Certificate No. : ATCC/18051502
Issue Date : 18.05.2018
Job order No. : 18051502
Test to be Conducted, As Per Party Requirement
Date of Test : 18.05.2018
Date of Sample Received : 16.05.2018
Party Ref. No. INDOMS/05/2018/62 Dated 16.05.2018

Quantity of Sample : 1 No
Sample Description : Indo Diver™ Bird Flight diverter (Model - BD-04F)

Sl.No.	Test Conducted, Specification As Per Party Requirement	Specified Value	Test Results
1	Strength Test		75.4 Kg

XXXXXXX END OF TEST REPORT XXXXXXX

Notes
(1) This Test Report refers only to the particular sample(s) submitted for testing. (2) This Test Report shall not be reproduced, except in full, unless written permission for the publication of an approved abstract has been obtained from the CEO, Amit Test and Calibration Centre, New Delhi. (3) Test Report shall not be utilized for any legal purpose and will not be produced in the court of law & no responsibility would be attached. Amit Test and Calibration Centre. (4) The test results reported in this certificate are valid at the time of and under the stated conditions of measurements.

MANOHAR SINGH JADON
Issued By: 
(C.E.O.)

Authorized Signatory 1 of 2
SADHANA JADON
(Quality Manager)



Indolite Devices Pvt.Ltd

Bird, Monkey & Wild Life Control Solutions



IndoDivert™ Bird Flight Diverter

Test Certificates from NABL Accredited Laboratory

AMIT TEST AND CALIBRATION CENTRE
(NABL ACCREDITED & BIS RECOGNISED LABORATORY)
19/168, Sarai Rohila, Old Rohtak Road, Near Usha Mata Mandir, New Delhi-110035, M. +91-9560959122
Phone : 011-23643995, 011-23643992, +91-9811196977 amittestcc@gmail.com Website : www.atccc.in

TEST REPORT

REPORT No.: ATCC 19100303
ULR: TC558419000000037P
Issue To: Indolite Devices Pvt. Ltd.
18, Raja Garden
New Delhi - 110015

Issue Date: 05.10.2019
Job order No.: 19100303
Test to be Conducted: As Per Party Requirement
Date of test: 03.10.2019
Date of Sample Received: 03.10.2019
Party Ref. No.: IND/MS/05/2019/65
Dated: 03.10.2019

Quantity of Sample : 1 No.
Clamp : OPGW
Sample Description : Indo Divert™ Wind Mill & Solar Zone

Test Conducted, SI.No.	Specification As Per Party Requirement	Specified Value	Test Results
1	Load Bearing Test		260 Kg

XXXXXXXXXX END OF TEST REPORT XXXXXXXXXXXX

Notes:
(1) This Test Report refers only to the particular sample(s) submitted for testing. (2) This Test Report shall not be reproduced, except in full, unless written permission for the publication of an approved abstract has been obtained from the CEO, Amit Test and Calibration Centre, New Delhi. (3) Test Report shall not be utilized for any legal purpose and will not be produced in the court of law & no responsibility would be attached to Amit Test and Calibration Centre. (4) The test results reported in this certificate are valid at the time of and under the stated conditions of measurements.

Issued By: MANOHAR SINGH JADON (C.E.O.)
Authorized Signatory: SADHANA JADON (Quality Manager)

AMIT TEST AND CALIBRATION CENTRE
(NABL ACCREDITED & BIS RECOGNISED LABORATORY)
19/168, Sarai Rohila, Old Rohtak Road, Near Usha Mata Mandir, New Delhi-110035, M. +91-9560959122
Phone : 011-23643995, 011-23643992, +91-9811196977 amittestcc@gmail.com Website : www.atccc.in

TEST REPORT

REPORT No.: ATCC 19100302
ULR: TC558419000000039P
Issue To: Indolite Devices Pvt. Ltd.
18, Raja Garden
New Delhi - 110015

Issue Date: 05.10.2019
Job order No.: 19100302
Test to be Conducted: As Per Party Requirement
Date of test: 03.10.2019
Date of Sample Received: 03.10.2019
Party Ref. No.: IND/MS/05/2019/65
Dated: 03.10.2019

Quantity of Sample : 1 No.
Clamp : AL/29/ZEBRAMOOSE
Sample Description : Indo Divert™ Wind Mill & Solar Zone

Test Conducted, SI.No.	Specification As Per Party Requirement	Specified Value	Test Results
1	Load Bearing Test		1300 Kg

XXXXXXXXXX END OF TEST REPORT XXXXXXXXXXXX

Notes:
(1) This Test Report refers only to the particular sample(s) submitted for testing. (2) This Test Report shall not be reproduced, except in full, unless written permission for the publication of an approved abstract has been obtained from the CEO, Amit Test and Calibration Centre, New Delhi. (3) Test Report shall not be utilized for any legal purpose and will not be produced in the court of law & no responsibility would be attached to Amit Test and Calibration Centre. (4) The test results reported in this certificate are valid at the time of and under the stated conditions of measurements.

Issued By: MANOHAR SINGH JADON (C.E.O.)
Authorized Signatory: SADHANA JADON (Quality Manager)

AMIT TEST AND CALIBRATION CENTRE
(NABL ACCREDITED & BIS RECOGNISED LABORATORY)
19/168, Sarai Rohila, Old Rohtak Road, Near Usha Mata Mandir, New Delhi-110035, M. +91-9560959122
Phone : 011-23643995, 011-23643992, +91-9811196977 amittestcc@gmail.com Website : www.atccc.in

TEST REPORT

REPORT No.: ULR-TC5584190000000232P
Issue To: Indolite Devices Pvt. Ltd.
18, Raja Garden
New Delhi-110015

Issue Date: 14.05.2019
Job Order No.: 19051003
Test to be Conducted: As Per Party Requirement
Date of Test: 10.05.2019 to 13.05.2019
Date of Sample Received: 10.05.2019
Party Ref. No.: IND/MS/05/2019/204
Dated: 05.05.2019

Quantity of Sample : 1 No.
Sample Description : Indo Divert- Bird Flight Diverter
Model No : BD-07
Identification Mark on sample : Indolite
Lot No. / Date of manufacture on sample : 05/19

Test Conducted, SI.No.	Specification As Per Party Requirement	Test Results	Conformity
1	Appearance	Shall be free from cracks.	yes
a	Dangler Visibility	Should Glow in Dark	yes
b	Light Reflectivity	Reflector on both sides of dangler	yes
2	Dimensions		
a	Overall Length	443 ± 5 mm	yes
b	Diameter of Dangler	225 ± 5 mm	yes
c	Reflector Diameter	90 ± 3 mm	yes
3.	Load Bearing Strength		
a	Suspended Load Bearing Capacity	20 Kg for 1 hour	yes
b	Clutch Holding Strength	Must hold upto 50 Kg	yes

XXXXXXXXXX END OF TEST REPORT XXXXXXXXXXXX

Notes:
(1) This Test Report refers only to the particular sample(s) submitted for testing. (2) This Test Report shall not be reproduced, except in full, unless written permission for the publication of an approved abstract has been obtained from the CEO, Amit Test and Calibration Centre, New Delhi. (3) Test Report shall not be utilized for any legal purpose and will not be produced in the court of law & no responsibility would be attached to Amit Test and Calibration Centre. (4) The test results reported in this certificate are valid at the time of and under the stated conditions of measurements.

Issued By: MANOHAR SINGH JADON (C.E.O.)
Authorized Signatory: SADHANA JADON (Quality Manager)

AMIT TEST AND CALIBRATION CENTRE
(NABL ACCREDITED & BIS RECOGNISED LABORATORY)
19/168, Sarai Rohila, Old Rohtak Road, Near Usha Mata Mandir, New Delhi-110035, M. +91-9560959122
Phone : 011-23643995, 011-23643992, +91-9811196977 amittestcc@gmail.com Website : www.atccc.in

TEST REPORT

REPORT No.: ULR-TC5584190000000232P



XXXXXXXXXX END OF TEST REPORT XXXXXXXXXXXX

Notes:
(1) This Test Report refers only to the particular sample(s) submitted for testing. (2) This Test Report shall not be reproduced, except in full, unless written permission for the publication of an approved abstract has been obtained from the CEO, Amit Test and Calibration Centre, New Delhi. (3) Test Report shall not be utilized for any legal purpose and will not be produced in the court of law & no responsibility would be attached to Amit Test and Calibration Centre. (4) The test results reported in this certificate are valid at the time of and under the stated conditions of measurements.

Issued By: MANOHAR SINGH JADON (C.E.O.)
Authorized Signatory: SADHANA JADON (Quality Manager)

Installation Process

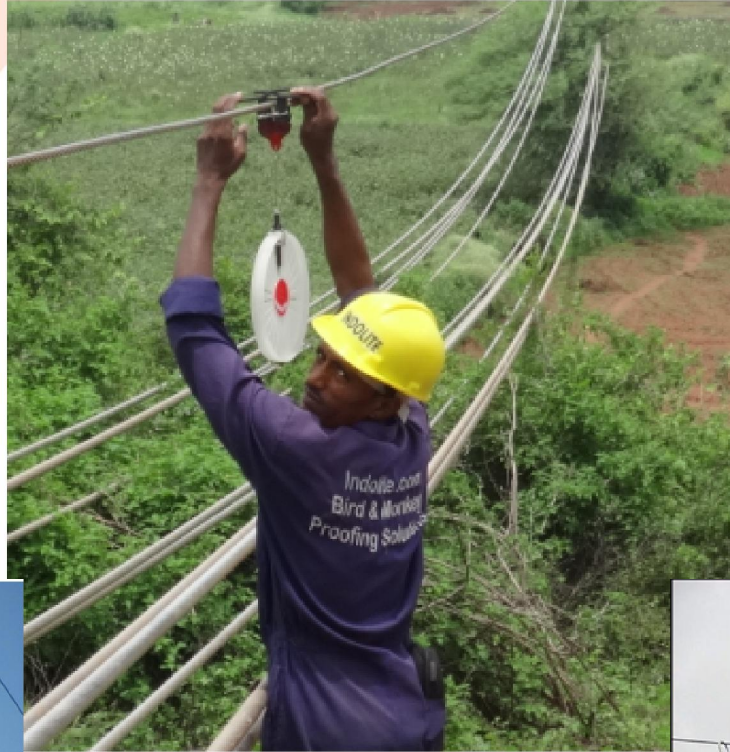

← Pre-Electrification



Post-Electrification →



Indolite Devices Pvt.Ltd

Installation Process Pre-Electrification



Fastening IndoDivert™ on Conductor

Besides spring loaded clamps, we have fastener type arrangement also in of our models

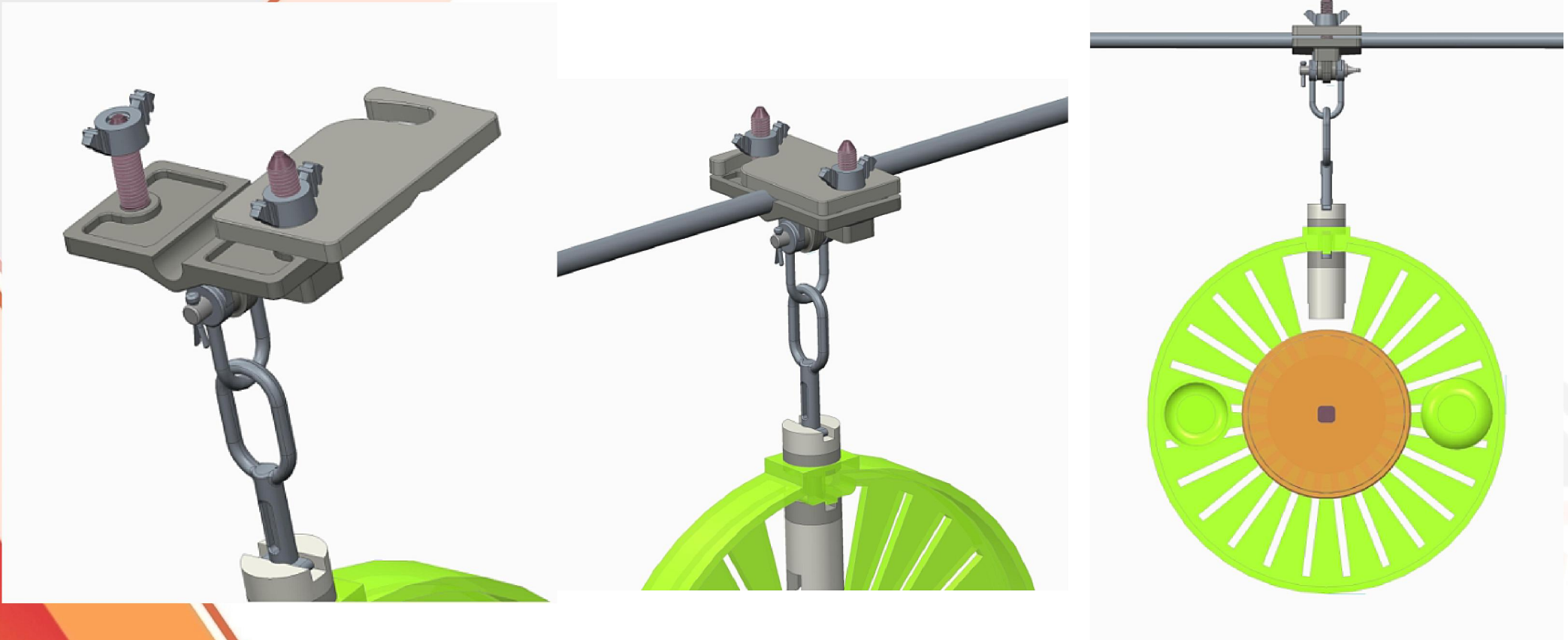

We Love Mother Nature

We sincerely work towards a healthy environment for our future generations

Verve and beyond: -

We stand by our products even after their life time.

We are obsessive about mother EARTH and LIFE on it. To leave a positive foot print for future life, we assure to recycle our products, once you are finished with these.

If you return these to us after their respective life time, we will recycle same and put it to use in every feasible way.



Hotel Clients ... to name a few

Client	Brief Client Profile
The LaLit	The Lalit Suri Hospitality Group, an enterprise of Bharat Hotels Limited is India's largest and the fastest growing privately owned Hotel Company.
The Oberoi	The Oberoi Group, founded in 1934, operates 30 hotels, a Nile Cruiser and a Motor Vessel in the backwaters of Kerala. The Group has presence in six countries under the luxury 'Oberoi' and five-star 'Trident' brand.
Claridges Hotel	Built in 1952, The Claridges New Delhi is an iconic hotel superbly located in at the heart of New Delhi's eminent address – Lutyen's Delhi and is a perfect blend of old world elegance and contemporary luxury, with the Capital's bustling commercial and cultural centres just a few steps away.
ITC Hotels	ITC Forayed into The Hotel is business to support the national priority of developing new avenues of foreign exchange earnings and boosting tourism. Beginning with the Sheraton Chola, Chennai in 1975, ITC's journey in this business has redefined the face of Indian hospitality.
Zuri Group Global Hotels.	Headquartered in Bangalore the Zuri group is promoted by a consortium of investors from the Middle East, the group began its India operations in 1999 with three hotel properties, all under franchise agreements with leading international hotel brands.



clients

Indolite Devices Pvt.Ltd

Our respectable clients...

Government Clients *...to name a few*

Client	Brief Client Profile
Delhi Metro Rail Corporation	The Delhi Metro Rail Corporation Ltd., abbreviated to DMRC, is a state owned company that operates the Delhi Metro. The DMRC is also involved in the planning and implementation of metro rail, monorail, and high-speed rail projects in India and abroad.
Airport Authority Of India	The Airports Authority of India (AAI) under the Ministry of Civil Aviation is responsible for creating, upgrading, maintaining and managing civil aviation infrastructure in India. It provides Air traffic management (ATM) services over Indian airspace and adjoining oceanic areas.
Indian Navy	The Indian Navy is the naval branch of the armed forces of India. The President of India serves as the Commander-in-Chief of the Navy. The Chief of Naval Staff (CNS), usually a four-star officer in the rank of admiral, commands the navy.
Delhi University	The University of Delhi is a public central university located in Delhi, India. It is the premier university of the country and is known for its high standards in teaching and research, as well as the eminent scholars it attracts to its faculty.



दिल्ली मेट्रो रेल कॉर्पोरेशन लिमिटेड
Delhi Metro Rail Corporation Limited



भारतीय विमानपत्तन प्राधिकरण
AIRPORTS AUTHORITY OF INDIA



indolite Devices Pvt.Ltd

Bird, Monkey & Wild Life Control Solutions



Government Clients *...to name a few*

Client	Brief Client Profile
Hon'ble Supreme Court of India	The Supreme Court of India is the highest judicial forum and final court of appeal under the Constitution of India, the highest constitutional court, with the power of constitutional review.
Jawaharlal Nehru Bhawan	Jawaharlal Nehru Bhawan, the headquarters office building of the Ministry of External Affairs at Janpath, New Delhi, is a contemporary state-of-the-art building in complete harmony with its environment and surrounding architecture of Edwin lutyen's.
Shastri Bhawan	Government offices for Ministries of Education, Petroleum, Chemicals and Fertilizers, Youth Affairs, Family welfare etc
Lieutenant Governor's House	The Lieutenant Governor of Delhi is the constitutional head of Delhi as well as the Government of Delhi.
Prime Minister's House	Our privilege to render services at Prime Minister's House at 7, Race Course Road, New Delhi is the constitutional head of Delhi as well as the Government of Delhi.



Embassy Clients *...to name a few*

Client	Brief Client Profile
Japan Embassy	The Ministry of Foreign Affairs (MOFA) will work to realize an easily accessible MOFA Website, which allows the elderly and people with disabilities to use the information and services provided on the site without any difficulties.
American Embassy	The Department of State is updating the Worldwide Caution to provide information on the continuing threat of terrorist actions and violence against U.S. citizens and interests throughout the world.
Austrian Embassy	Austria is a landlocked country of approximately 8.5 million inhabitants in Central Europe. It is bordered by the Czech Republic and Germany to the north, Slovakia and Hungary to the east, Slovenia and Italy to the south, and Switzerland and Liechtenstein to the west.
Australian High Commission	The Australian Consulate General in Delhi represents the interests of the Australian government in the India.
British High Commission	The British High Commission in Delhi represents the interests of the British government in the India.



EMBASSY OF JAPAN



Austrian Embassy



AUSTRALIAN CONSULATE-GENERAL
AUSTRALIAN GOVERNMENT



British High Commission
Bridgetown

Hospital Clients *... to name a few*

Client	Brief Client Profile
Fortis	Fortis Healthcare Limited is a leading, pan Asia-Pacific, integrated healthcare delivery provider.
Max Health Care	At Max Super Specialty Hospitals, it is our level of service and eye for detailing in everything that we do, that truly sets us apart and makes us the care provider of choice for millions of patients
Handa Stone Clinic	Handa Nursing Home is a well established nursing home at Raja Garden (West-Delhi). It is in existence since 1984. It is rendering quality health care to the community. It is an advanced center for Laparoscopic Surgery since 1992.
Dr. B L Kapur Memorial Hospital	BLK Super Specialty Hospital is the largest stand-alone private sector hospital in Delhi. The Hospital has a capacity of 650 beds with dedicated 125 critical care beds with over 150 specialists across various super specialties making it one of the best hospitals in India. BLK's comprehensive Cancer Care with organ specific specialist teams makes it best Cancer Hospital in India.
SUT Hospital	The first multi-specialty hospital in Kerala, SUT Hospital offers dedicated medical and surgical treatments with 24hour emergency services.



Indolite Devices Pvt.Ltd



Bird, Monkey & Wild Life Control Solutions

Hotel Clients *... to name a few*

Client	Brief Client Profile
Country Inn & Suites by Carlson	The brand currently operates more than 465 hotels throughout the world. New build, acquisitions and select conversions are all part of our aggressive growth plan.
Leonia Holistic Destination	Leonia Holistic Destination is India's first and the world's finest themed destination near the city of Hyderabad, India. Leonia shall soon launch another upper upscale hotel of 1000 rooms and Asia's largest water park.
Fortune Park Hotels Ltd.	Fortune, a member of ITC's hotel group, was set up in 1995 to cater to the mid-market to upscale segment in business and leisure destinations. It has emerged as one of the fastest growing 'first-class, full-service business hotel' chains in India.
Crowne Plaza	Crowne Plaza is a chain of full service, upscale hotel is catering to business travelers and to the meetings and conventions market.
OBEROI Hotels and Resorts Limited	One of the most renowned Indian Brand with world wide presence



Clients

Indolite Devices Pvt.Ltd

FMCG Clients ... to name a few

Client	Brief Client Profile
Kohinoor Foods Limited	Kohinoor Foods Ltd. embarked upon its journey in 1989. Since then it has been treating every milestone achieved as a stepping stone to go past another one.
Britannia Industries Limited	The story of one of India's favourite brands reads almost like a fairy tale. Once upon a time, in 1892 to be precise, a biscuit company was started in a nondescript house in Kolkata.
Haldiram Snacks Pvt Ltd.	Haldiram's is a major Indian sweets and snacks manufacturer in India. Haldiram a familiar singh on sheves across the USA, UK and Middle East.
Glaxo Smithkline Consumer Health Care Ltd.	At GlaxoSmithKline, we recognize that there is no achievement without integrity. as we chase our business goals and our daily task lists, we are guided by the GSK Spririk.
Bikaner	BFAP is a company dealing in the business of exporting agricultural commodities. BFAP is managed by a good mix of experienced & young professionals.
REI Agro Limited	Raindrops basmati rice comes from the house of REI Agro Limited – World's largest basmati processing company. REI Agro Ltd was established in the year 1994 with a vision to consolidate the fragmented basmati rice industry.
Coca Cola	Coca-Cola is a carbonated soft drink sold in stores, restaurants, and vending machines throughout the world.



Indolite Devices Pvt.Ltd



Client	Brief Client Profile
HCL	Over the past decade, HCL has been one of the fastest growing technology companies not only in India but in the world – even during the depths of the economic downturn.
Idea	Idea Cellular is an Aditya Birla Group Company, India's first truly multinational corporation. Idea is a pan-India integrated GSM operator offering 2G and 3G services, and has its own NLD and ILD operations, and ISP license.
Hindustan Times	HT Media found its beginning in 1924 when its flagship newspaper, Hindustan Times was inaugurated by Mahatma Gandhi. HT Media (BSE, NSE) has today grown to become one of India's largest media companies.
Ansal Properties & Infrastructure Ltd.	Established in 1967 with a vision of quality and on-time delivery, Ansal API today is one of the leading real estate developers in India.
Himalayan Development Foundation	Himalayan Development Foundation is a 501(c)(3) organization providing charitable, educational, and community development assistance in India & Nepal.
Ashoka Estate Maintenance Society	This is a maintenance Company.



Indolite Devices Pvt.Ltd

Private Sector Clients ... to name a few

Client	Brief Client Profile
City Square	A premier shopping mall in one of the most stylish locations of Delhi, City Square has carved a niche for itself in a short span of time. With 100% occupancy, the mall has it all, from apparel stores and snack joints to a food court.
Sheraton Group	The Sheraton Stockholm Hotel is situated in the heart of Stockholm's central business district, our great location allows you to explore and connect to our wonderful city
Ace Honda	Ace Honda, is the exclusive authorized Honda Car Dealer in Noida, Up, We Cater to the areas of Noida, Greater Noida, East Delhi, Ghaziabad and South Delhi.
Birla Tower	A Birla Towers is a tall structure, usually taller than it is wide, often by a significant margin. Birla Towers are distinguished from masts by their lack of guy-wires.
PSL Engineering Limited	The Group comprises of several companies which are involved in manufacturing of Air Conditioners, Chillers, Heat Exchangers and Radiators.
SAI Fasteners Limited	SAI is a leading manufacturer of Stainless Steel Fasteners from last 15 years, with a capacity 800 MT per year.



Sheraton



Clients

Indolite Devices Pvt.Ltd

Bird, Monkey & Wild Life Control Solutions



Private Sector Clients ... to name a few

Client	Brief Client Profile
Areva T&D India Ltd	AREVA is an international company focused on providing India with solutions for low-carbon power generation, both nuclear and renewables
Bosch Limited	As the world's largest independent parts supplier to the automotive industry, we significantly contribute toward making driving ever safer, cleaner, and more economical.
Cargill India Pvt. Ltd.	Cargill provides food, agriculture, financial and industrial products and services to the world. Together with farmers, customers, governments and communities, we help people thrive by applying our insights and nearly 150 years of experience.
Polyplex Corporation Limited	Polyplex Corporation Ltd. (Polyplex) is among the world's largest manufacturers of thin PET film. We run integrated manufacturing & distribution operations in six countries viz. India, Thailand, Turkey, U.S.A., China & Netherlands.
Delhi Public School	The DPS Society is a non-profit, non-proprietary, private, educational organization. This Global Network of over 200 English medium, co-educational, secular schools provides education from Pre-Nursery/Nursery to Class XII.
Ever Sun Energy Pvt. Ltd.	Solar energy products.



Indolite Devices Pvt.Ltd

THANK YOU

Indolite Devices Private Limited
18, Raja Garden,
New Delhi
Pin Code- 110015
INDIA

E_mail:sales@indolite.com
Phone:+91-11-4514 9599
Fax:+91-11-2511 9265
Mobile:+91- 850-607-0808

Indolite Devices Pvt.Ltd

Bird, Monkey & Wild Life Control Solutions

